

# BASELIFT Corner 6302 / 6312

Wall-mounted or floor-mounted motorised corner worktop lift, 45° front edge, 45° wall



Corner worktop lift with 45° slanted front edge and rear edge gives the kitchen an exclusive look, while providing good access to the work surfaces on the sides. Installations under the worktop are hidden by cover panels.

BASELIFT Corner 6302/6312 is a motorised corner worktop lift with 45° front edge and 45° rear edge. Choose between wall-mounted or floor-mounted motors.

Under the worktop, space is left for the knees and legs. Installations under the worktop, (motors, water, sewers) can be concealed with telescopic cover panels which gives the kitchen a neat look.

The motors work steplessly and adjust the worktop quickly and quietly to the desired height. The lift is equipped with a reliable safety system that guarantees safe operation without any risk of pinching. The lift is prepared in the factory to facilitate easy installation.

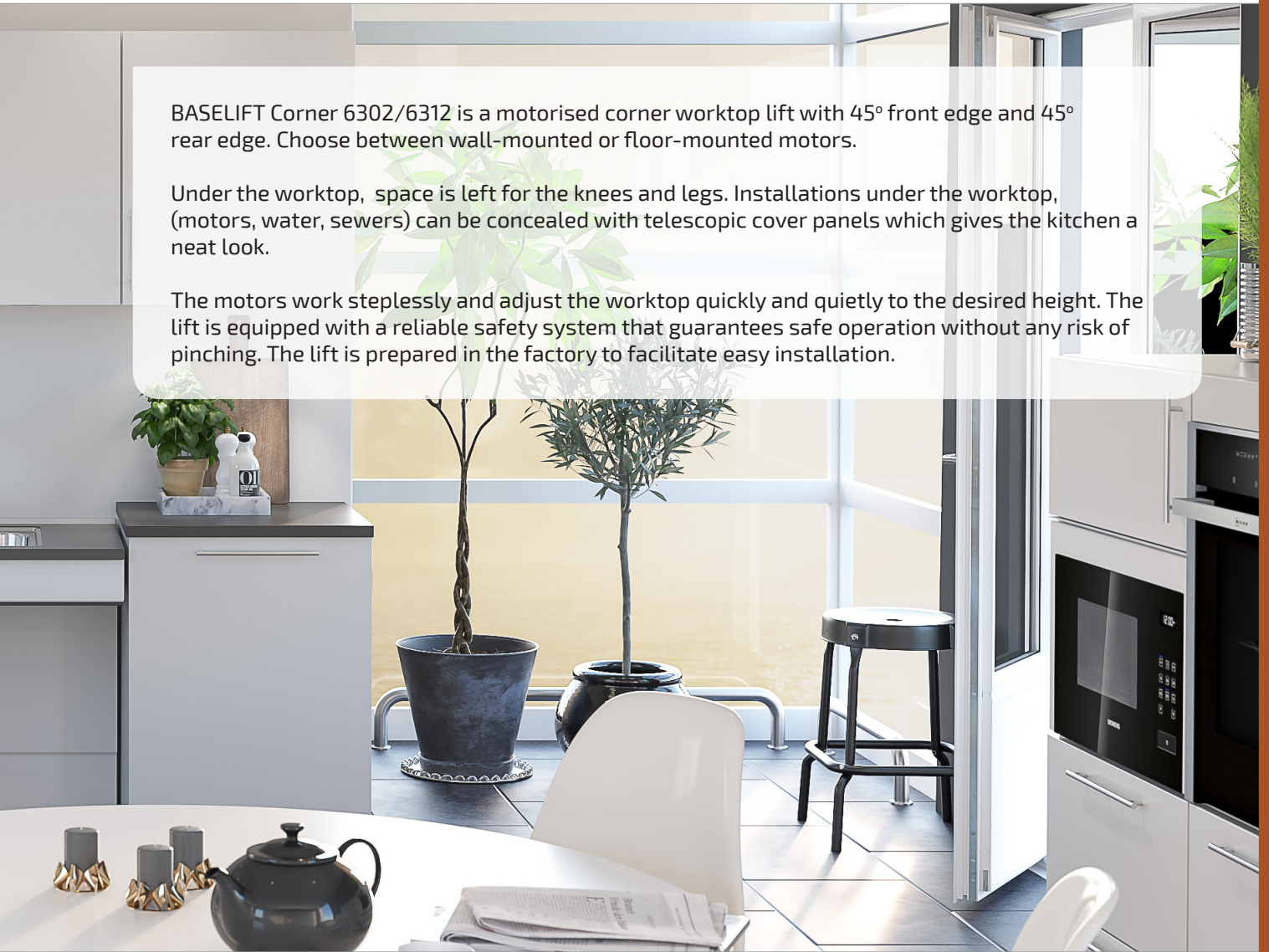

Hob can be integrated with the corner module. It is also possible to integrate the inset sink with a sink bowl in the corner module.



A drawer can be integrated with the worktop.



### Functions and advantages

- Motorised corner worktop lift, 45° front edge, 45° wall
- Hob or sink bowl can be mounted in the corner module
- Height-adjustable 70-100 cm above the floor (excl. top board)
- The frame depth is adjustable 56-59 cm to fit adjoining cabinet
- The upper part of the lifting system is delivered ready-mounted. The sides are pre-assembled and adjustable side-ways to suit the sink, hob and drawers
- The lifting system is adjustable at an angle to compensate for an inclined wall
- Integrated safety switch
- 10 cm free space under motors for electrical installation and piping. (Applies to wall-mounted model)
- Choose floor-mounted model if there is no stable wall

### Standard equipment

- Factory-mounted aluminium system with movable and tiltable brackets
- Wall-mounted or floor-mounted motors
- Safety switch

### Recommended additional options

- Control button
- Front
- Hose cover/cover panels
- Sink (Not 6302L/6312L)
- Drawer (Not 6302L/6312L)
- Rear edge trim
- Top board
- Hob

### Useful information

- Fittings for top board and fronts enclosed
- The top board's depth must be 15 mm shallower than adjoining top boards (to provide a gap for tiles and movement)
- Width of the top board = width of the lift
- Sink bowls with a maximum height of 120 mm can be integrated (Not 6302L/6312L)
- Electronics and motor system "Plug and Play"
- Width of front = width of lift - 4 mm  
Height of front: 6302H/6312H = 103 mm, 6302L/6312L = 40 mm  
Fittings enclosed
- Cover panels can hide installations under the worktop  
2 pcs, height 438 mm, thickness 12-20 mm

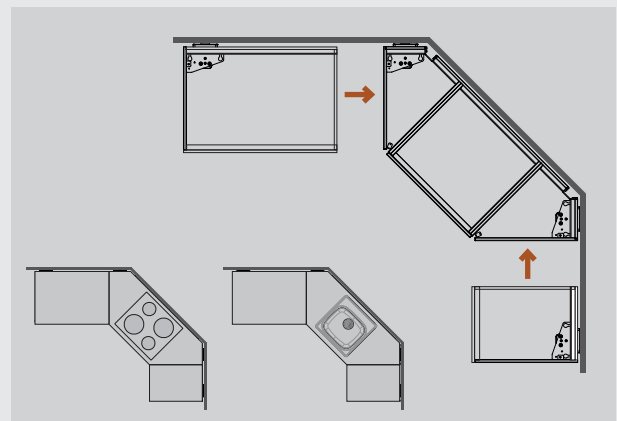

The corner module is equipped with two motors and can be used as one unit. Supplement with Plus modules to obtain the desired length on the left and right wings. A hob or sink bowl can be placed in the corner.

Specify the position of the drawers, sink and hob  
The worktop is prepared in the factory. Drawers are mounted and sides assembled to facilitate the final mounting on the spot.

WALL-MOUNTED

6302H



6302L



FLOOR-MOUNTED

6312H



6312L



Specifications

<b>Mounting</b>	Wall or floor
<b>Corner solution</b>	45° front edge, 45° wall
<b>Height adjustment</b>	Motorised, steplessly adjustable 300 mm (700-1000 mm excl. top board)
<b>Speed</b>	30 mm / sec.
<b>Manoeuvring</b>	Recessed mounted button or radio control
<b>Safety</b>	The safety strip is placed under the front edge of the worktop. If anything touches the safety strip, the lifting unit stops
<b>Electricity connection</b>	Plug for 230 V, max 5.0 A
<b>Plumbing connections</b>	Connection is made with flexible hoses
<b>Lifting power</b>	100 kg
<b>IP Class</b>	IP 20
<b>Frame depth</b>	560-590 mm from wall
<b>Front height</b>	40 or 103 mm
<b>Dimensions cover panels</b>	2 pcs, height 438 mm, thickness 12-20 mm
<b>Width top board</b>	Width = width of the lift
<b>Depth top board</b>	565-630 mm (15 mm shallower than worktops on fixed cabinets)
<b>Gap to the side to wall/adjoining cabinet</b>	5 mm
<b>Gap to wall (for tiling)</b>	15 mm
<b>Tiling</b>	From 700 mm above floor (alternatively all the way down to the floor)
<b>Delivery modules</b>	Ready-mounted worktop incl. safety switch, motors
<b>Fittings enclosed</b>	Bracket for fronts and top board
<b>Material specifications</b>	Aluminium frame
<b>Guarantee</b>	2 years
	<b>CE</b>

Measurement data

(mm)

WALL-MOUNTED: 6302H/6302L

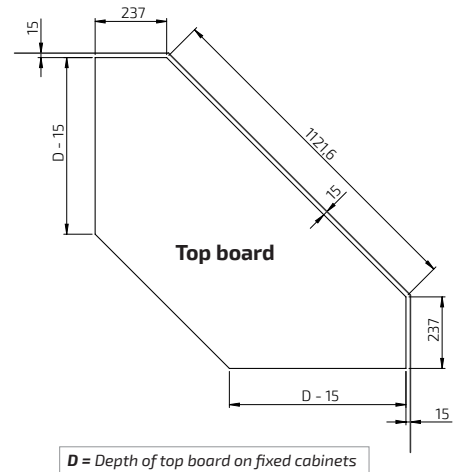
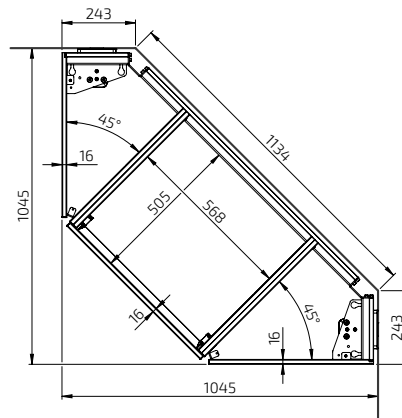
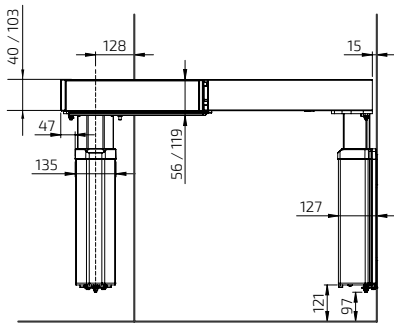

FLOOR-MOUNTED: 6312H / 6312L

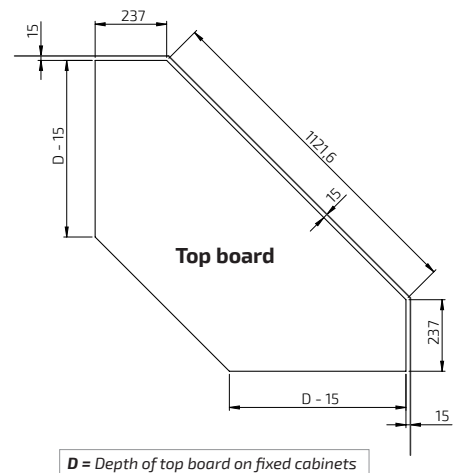
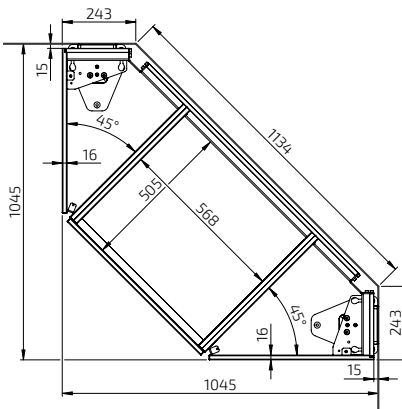
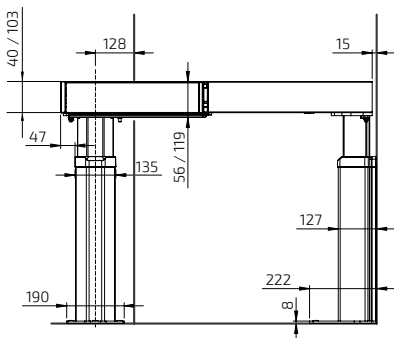

**BASELIFT Corner 6302HA - Wall-mounted**

Lifting unit 104.5 x 104.5 cm  
 For 103 mm front  
 Frame depth 56.0 - 59.0 cm  
 2 motors  
 Safety switch



**BASELIFT Corner 6302HA - Floor-mounted**

Lifting unit 104.5 x 104.5 cm  
 For 103 mm front  
 Frame depth 56.0 - 59.0 cm  
 2 motors  
 Safety switch



	Width (cm)	Art. no.
	104.5	6302HA-1045

	Width (cm)	Art. no.
	104.5	6312HA-1045

**Plus module Left 6305HA, 40.0-100.0 cm**



40.0	6305HA-040
50.0	6305HA-050
60.0	6305HA-060
70.0	6305HA-070
80.0	6305HA-080
90.0	6305HA-090
100.0	6305HA-100

**Plus module Left 6315HA, 40.0 - 100.0 cm**



40.0	6315HA-040
50.0	6315HA-150
60.0	6315HA-060
70.0	6315HA-070
80.0	6315HA-080
90.0	6315HA-090
100.0	6315HA-100

**Plus module Left 6305HA, 110.0-180.0 cm**



110.0	6305HA-110
120.0	6305HA-120
130.0	6305HA-130
140.0	6305HA-140
150.0	6305HA-150
160.0	6305HA-160
170.0	6305HA-170
180.0	6305HA-180

**Plus module Left 6315HA, 110.0 - 180.0 cm**



110.0	6315HA-110
120.0	6315HA-120
130.0	6315HA-130
140.0	6315HA-140
150.0	6315HA-150
160.0	6315HA-160
170.0	6315HA-170
180.0	6315HA-180

**Plus module Left 6305HA, 190.0-240.0 cm**



190.0	6305HA-190
200.0	6305HA-200
210.0	6305HA-210
220.0	6305HA-220
230.0	6305HA-230
240.0	6305HA-240

**Plus module Left 6315HA, 190.0 - 240.0 cm**



190.0	6315HA-190
200.0	6315HA-200
210.0	6315HA-210
220.0	6315HA-220
230.0	6315HA-230
240.0	6315HA-240

**Plus module Right 6306HA, 40.0-100.0 cm**



40.0	6306HA-040
50.0	6306HA-050
60.0	6306HA-060
70.0	6306HA-070
80.0	6306HA-080
90.0	6306HA-090
100.0	6306HA-100

**Plus module Right 6316HA, 40.0 - 100.0 cm**



40.0	6316HA-040
50.0	6316HA-050
60.0	6316HA-160
70.0	6316HA-070
80.0	6316HA-080
90.0	6316HA-090
100.0	6316HA-100

**Plus module Right 6306HA, 110.0 - 180.0 cm**



110.0	6306HA-110
120.0	6306HA-120
130.0	6306HA-130
140.0	6306HA-140
150.0	6306HA-150
160.0	6306HA-160
170.0	6306HA-170
180.0	6306HA-180

**Plus module Right 6316HA, 110.0 - 180.0 cm**



110.0	6316HA-110
120.0	6316HA-120
130.0	6316HA-130
140.0	6316HA-140
150.0	6316HA-150
160.0	6316HA-160
170.0	6316HA-170
180.0	6316HA-180

**Plus module Right 6306HA, 190.0 - 180.0 cm**























190.0	6306HA-190
200.0	6306HA-200
210.0	6306HA-210
220.0	6306HA-220
230.0	6306HA-230
240.0	6306HA-240

**Plus module Right 6316HA, 190.0 - 240.0 cm**

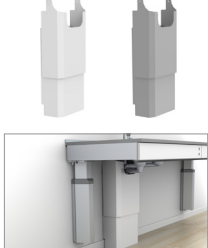
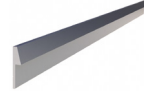

190.0	6316HA-190
200.0	6316HA-200
210.0	6316HA-210
220.0	6316HA-220
230.0	6316HA-230
240.0	6316HA-240

	<p><b>Control button in ALU-design</b> Wired, for recessed mounting Dimensions: 82 x 82 x 17 mm</p>	61320
	<p><b>Control button, Mini</b> Wired, for recessed mounting Diameter: 20 mm</p>	61318
	<p><b>Radio control - Hand control</b> Dimensions: 38 x 110 x 10 mm</p> <p>For one lift</p> <p>For two lifts</p> <p>For three lifts</p> <p>For four lifts</p> <p>For five lifts</p>	61385
		61387
		61388
		61389
		61390
	<p><b>Multi-compartment frame, ALU-design</b> Collects power socket, power switch or control buttons in a multi-compartment frame.</p> <p>Two-compartment frame: 153 x 82 x 9 mm</p> <p>Three-compartment frame: 225 x 82 x 9 mm</p>	61352 61353
	<p><b>Socket, ALU-design</b> Earthed socket 230 V with flap cover. Dimensions: 82 x 82 x 17 mm Only Europe</p>	61330
	<p><b>Power switch, ALU-design</b> For lighting, for example. The button has a sign for optional marking. Dimensions: 82 x 82 x 17 mm</p>	61331
	<p><b>Safety lock</b> Prevents unauthorised use. Dimensions: 23 x 9 mm</p>	61360
	<p><b>Front, white-lacquered aluminium</b> Replace xxx with cm when ordering. Example, 385H-040-01 for 40.0 cm</p> <p>Lacquered aluminium, white RAL 9003 Height: 103 mm Optional length, 20.0-340.0 cm</p>	385H-xxx-01
	<p><b>Front, anodised aluminium</b> Replace xxx with cm when ordering. Example, 385H-040-06 for 40.0 cm</p> <p>Anodised aluminium Height: 103 mm Optional length, 20.0-340.0 cm</p>	385H-xxx-06
	<p><b>Integrated drawer with full extension and soft-close or push-to-open function</b> Depth: 470 mm, height: 85 mm Colour: Anthracite (RAL 9004)</p>	465H-030 465H-040 465H-050 465H-060 465H-080 466H-030 466H-040 466H-050 466H-060 466H-080

	<p><b>Cutlery compartment</b></p> <p>Fits 30.0 cm wide drawer</p> <p>Fits 40.0 cm wide drawer</p> <p>Fits 50.0 cm wide drawer</p> <p>Fits 60.0 cm wide drawer</p> <p>Fits 80.0 cm wide drawer</p>	463-030 463-040 463-050 463-060 463-080
	<p><b>Safety strip</b> Used if pinch protection is desired on the gable end (by an open side). Length: 370 mm, Height: 10 mm</p>	61430
	<p><b>Safety panel, short end</b> Used when the worktop lift's underside passes over adjoining furnishings. Height: 263 - 800 mm, Depth: 400 mm <b>For a worktop lift with cover panels</b></p>	Left 61442 Right 61443
	<p><b>Safety panel, short end</b> Used when the worktop lift's underside passes over adjoining furnishings. Height: 263 - 800 mm, Depth: 545 mm <b>For a worktop lift without cover panels</b></p>	Left 61444 Right 61445
	<p><b>Hob cover under worktop lift</b> Provides a smooth underside. Used under the hob.</p> <p>White-lacquered metal RAL 9003</p>	60.0 cm 6266-060 70.0 cm 6266-070 80.0 cm 6266-080 90.0 cm 6266-090 100.0 cm 6266-100
	<p><b>Cover panels</b> Used to cover installations under the worktop.</p> <p>12 mm white melamine, 2 pcs height 438 mm 2 pcs are required for lengths over 2400 mm</p>	6260-240
	<p><b>Fittings set for cover panels</b> Used to mount cover panels that conceal installations under the worktop.</p> <p>Colour: Alu-grey RAL 9006 2 pcs are required for lengths over 2400 mm</p>	6260-005
	<p><b>Hose cover</b> The hose cover is mounted anywhere under the worktop, (next to motors, if applicable) to provide a neat coverage of hoses when the cover panels are not in use. Fittings are included.</p> <p>Width: 410 mm, Depth: 200 mm</p>	White plastic 61504-01 Grey plastic 61504-06
	<p><b>Rear edge trim in aluminium for top board</b> Mounted behind top board. Brushed aluminium Height above top board: 20 mm Thickness behind top board: 3 mm (per metre)</p>	6943-06
	<p><b>Height-adjustment kit</b> Used to change stroke after installation. Contains programming box and memory adapter.</p>	61400

**BASELIFT Corner 6302LA - Wall-mounted**

Lifting unit 104.5 x 104.5 cm  
 For 40 mm front  
 Frame depth 56.0 - 59.0 cm  
 2 motors  
 Safety switch



**BASELIFT Corner 6312LA - Floor-mounted**

Lifting unit 104.5 x 104.5 cm  
 For 40 mm front  
 Frame depth 56.0 - 59.0 cm  
 2 motors  
 Safety switch



	Width (cm)	Art. no.
	104.5	6302LA-1045

	Width (cm)	Art. no.
	104.5	6312LA-1045

**Plus module Left 6305LA, 40.0-100.0 cm**



40.0	6305LA-040
50.0	6305LA-050
60.0	6305LA-060
70.0	6305LA-070
80.0	6305LA-080
90.0	6305LA-090
100.0	6305LA-100

**Plus module Left 6315LA, 40.0 - 100.0 cm**



40.0	6315LA-040
50.0	6315LA-150
60.0	6315LA-060
70.0	6315LA-070
80.0	6315LA-080
90.0	6315LA-090
100.0	6315LA-100

**Plus module Left 6305LA, 110.0-180.0 cm**



110.0	6305LA-110
120.0	6305LA-120
130.0	6305LA-130
140.0	6305LA-140
150.0	6305LA-150
160.0	6305LA-160
170.0	6305LA-170
180.0	6305LA-180

**Plus module Left 6315LA, 110.0 - 180.0 cm**



110.0	6315LA-110
120.0	6315LA-120
130.0	6315LA-130
140.0	6315LA-140
150.0	6315LA-150
160.0	6315LA-160
170.0	6315LA-170
180.0	6315LA-180

**Plus module Left 6305LA, 190.0-240.0 cm**



190.0	6305LA-190
200.0	6305LA-200
210.0	6305LA-210
220.0	6305LA-220
230.0	6305LA-230
240.0	6305LA-240

**Plus module Left 6315LA, 190.0 - 240.0 cm**



190.0	6315LA-190
200.0	6315LA-200
210.0	6315LA-210
220.0	6315LA-220
230.0	6315LA-230
240.0	6315LA-240

**Plus module Right 6306LA, 40.0 - 100.0 cm**



40.0	6306LA-040
50.0	6306LA-050
60.0	6306LA-060
70.0	6306LA-070
80.0	6306LA-080
90.0	6306LA-090
100.0	6306LA-100

**Plus module Right 6316LA, 40.0 - 100.0 cm**



40.0	6316LA-040
50.0	6316LA-050
60.0	6316LA-160
70.0	6316LA-070
80.0	6316LA-080
90.0	6316LA-090
100.0	6316LA-100

**Plus module Right 6306LA, 110.0 - 180.0 cm**



110.0	6306LA-100
120.0	6306LA-120
130.0	6306LA-130
140.0	6306LA-140
150.0	6306LA-150
160.0	6306LA-160
170.0	6306LA-170
180.0	6306LA-180

**Plus module Right 6316LA, 110.0 - 180.0 cm**



110.0	6316LA-110
120.0	6316LA-120
130.0	6316LA-130
140.0	6316LA-140
150.0	6316LA-150
160.0	6316LA-160
170.0	6316LA-170
180.0	6316LA-180

**Plus module Right 6306LA, 190.0 - 240.0 cm**

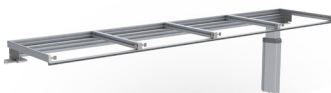











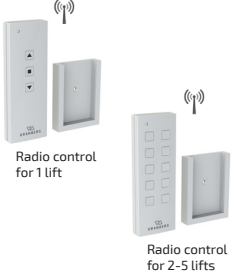

190.0	6306LA-190
200.0	6306LA-200
210.0	6306LA-210
220.0	6306LA-220
230.0	6306LA-230
240.0	6306LA-240

**Plus module Right 6316LA, 190.0 - 240.0 cm**

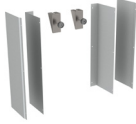
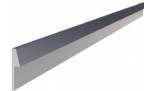

190.0	6316LA-190
200.0	6316LA-200
210.0	6316LA-210
220.0	6316LA-220
230.0	6316LA-230
240.0	6316LA-240

	<p><b>Control button, Mini</b></p> <p>Wired, for recessed mounting Diameter: 20 mm</p> <p>61318</p>		<p><b>Safety strip</b></p> <p>Used if pinch protection is desired on the gable end (by an open side). Length: 370 mm Height: 10 mm</p> <p>61430</p>
 <p>Radio control for 1 lift</p> <p>Radio control for 2-5 lifts</p>	<p><b>Radio control - Hand control</b> Dimensions: 38 x 110 x 10 mm</p> <p>For one lift 61385</p> <p>For two lifts 61387</p> <p>For three lifts 61388</p> <p>For four lifts 61389</p> <p>For five lifts 61390</p>		<p><b>Safety panel, short end</b> Used when the worktop lift's underside passes over adjoining interior fittings. Height: 263 mm, Depth: 400 mm <b>For a worktop lift with cover panels</b></p> <p>Left 61442</p> <p>Right 61443</p>
	<p><b>Safety lock</b> Prevents unauthorised use. Dimensions: 23 x 9 mm</p> <p>61360</p>		<p><b>Safety panel, short end</b> Used when the worktop lift's underside passes over adjoining furnishings. Height: 263 mm, Depth: 545 mm <b>For a worktop lift without cover panels</b></p> <p>Left 61444</p> <p>Right 61445</p>
	<p><b>Front, white-lacquered aluminium</b></p> <p>Replace xxx with cm when ordering. Example, 385L-040-01 for 40.0 cm</p> <p>Lacquered aluminium, white RAL 9003 Height: 40 mm Optional length, 20.0-340.0 cm</p> <p>385L-xxx-01</p>		<p><b>Hob cover under worktop lift</b></p> <p>Provides a smooth underside. Used under the hob.</p> <p>White-lacquered metal RAL 9003</p> <p>60.0 cm 6266-060</p> <p>70.0 cm 6266-070</p> <p>80.0 cm 6266-080</p> <p>90.0 cm 6266-090</p> <p>100.0 cm 6266-100</p>
	<p><b>Front, anodised aluminium</b></p> <p>Replace xxx with cm when ordering. Example, 385L-040-06 for 40.0 cm</p> <p>Anodised aluminium Height: 40 mm Optional length, 20.0-340.0 cm</p> <p>385L-XXX-06</p>		<p><b>Cover panels</b> Used to cover installations under the worktop.</p> <p>Length is adapted to worktop lift's length.</p> <p>12 mm white melamine, 2 pcs height 438 mm 2 pcs are required for lengths over 2400 mm</p> <p>6260-240</p>
			<p><b>Fittings set for cover panels</b> Used to mount cover panels that conceal installations under the worktop.</p> <p>Colour: Alu-grey RAL 9006 2 pcs are required for lengths over 2400 mm</p> <p>6260-005</p>
			<p><b>Rear edge trim in aluminium for top board</b> Mounted behind top board. Brushed aluminium Height above top board: 20 mm Thickness behind top board: 3 mm (per metre)</p> <p>6943-06</p>
			<p><b>Height-adjustment kit</b> Used to change stroke after installation. Contains programming box and memory adapter.</p> <p>61400</p>